

AASHTOWare BrR 6.8

Truss Tutorial

T2 – Truss Input Command

BrR Training

T2 – Truss Input Command

This training is comprised of 5 Truss Input Command exercises to modify the “North Truss” in T1 - Truss Floorbeam Stringer Example. Solutions are presented after all the exercises.

The exercises covered:

1. Modify truss geometry
2. Add new member cross section and assign cross section to member
3. Symmetry command
4. Add point load and additional self weight
5. Add member of interest to define deterioration

Note: It is assumed that the user is familiar with BrR and its Bridge Workspace and the user has completed T1 - Truss Floorbeam Stringer Example.

Truss Description

Trusses are described in BrR by entering a text description of the truss in the BrR Truss Command Language. This command language contains commands to describe the truss geometry, members, loads, etc. The Truss Command Language User Manual can be accessed from the BrR Truss window’s help topic. The help topic can be accessed by the F1 key when the BrR Truss window is in focus.

Exercise 1

The truss geometry described in T1 - Truss Floorbeam Stringer Example is shown below.

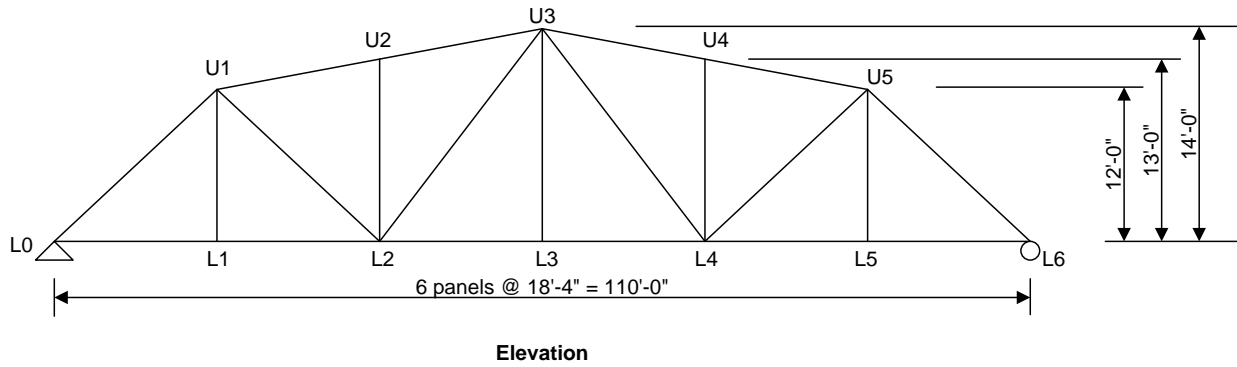

Modify the truss elevations and the second and fifth panels as shown below.

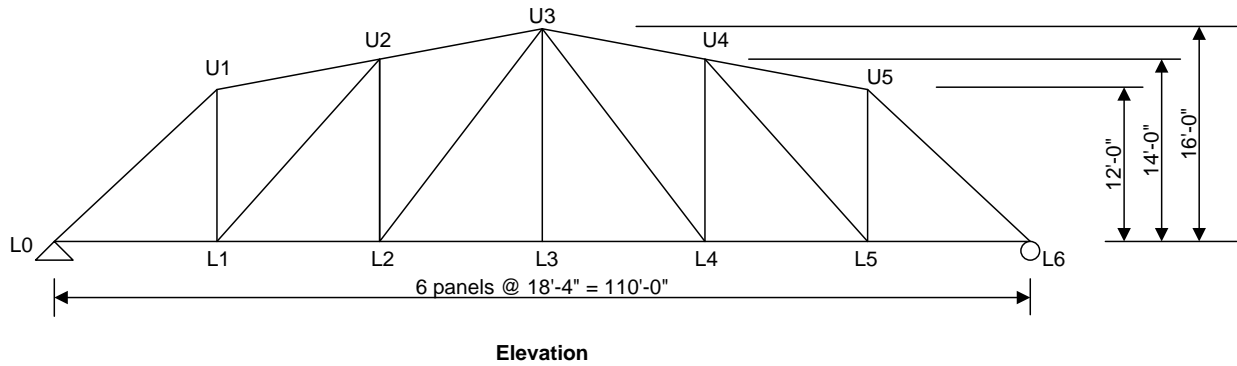

Exercise 2

Add the new member cross section as shown below and assign the cross section to the diagonal member in the second and fifth panels of the truss.

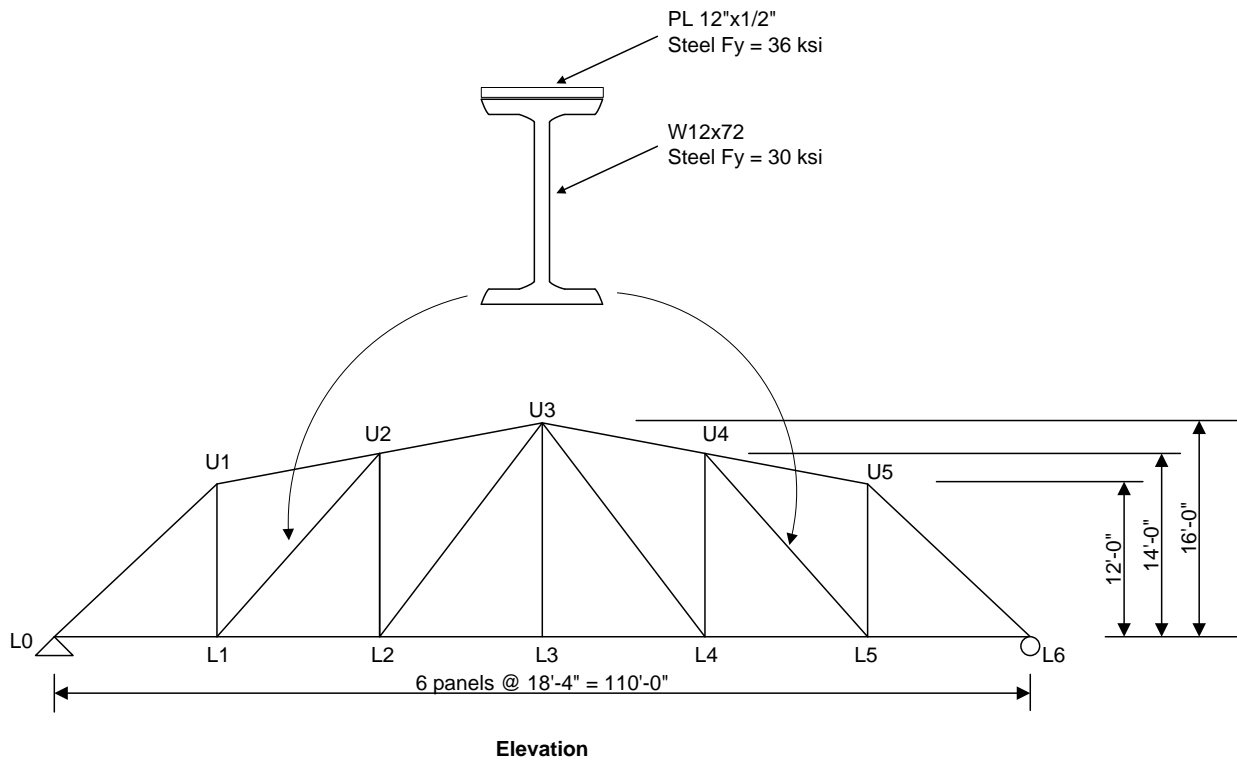

Exercise 3

Use the Symmetry command to describe the geometry as shown below.

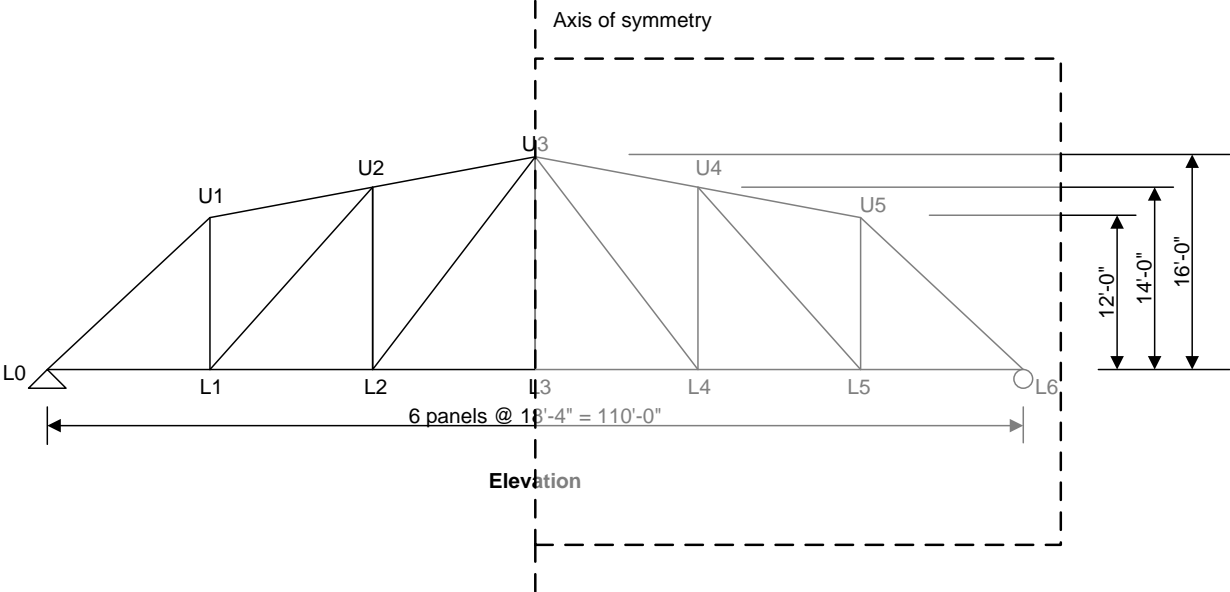

Exercise 4

Add the following additional loads to the truss:

10 kip downward vertical DC load at PanelPoint L2

Additional 5% self weight

Exercise 5

Add a member of interest to describe the following section loss in Member L0L1.

30% thickness section
loss on both channels

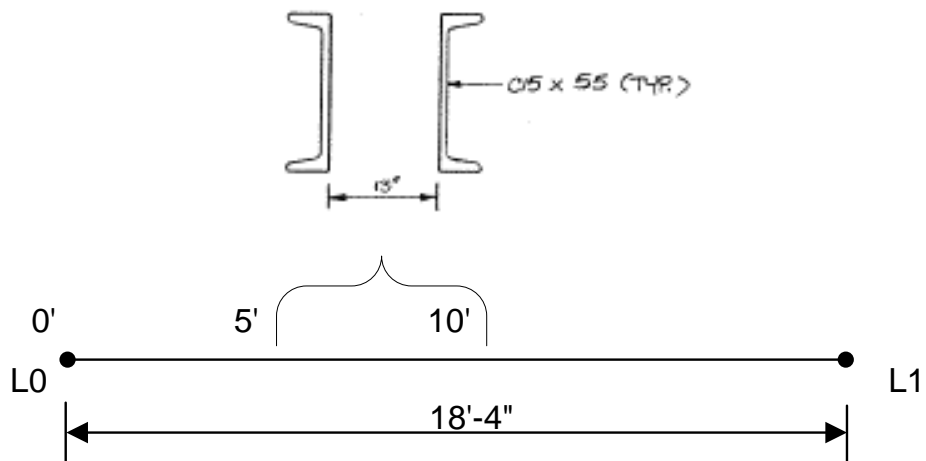

T2 – Truss Input Command

Exercise 1 Solution

The PanelPoint and Member commands for Exercise 1 are shown below. The modified descriptions are shown in bold text.

```
PanelPoint
L0 Lower 0.0000 0.0
L1 Lower 18.3333 0.0
L2 Lower 36.6667 0.0
L3 Lower 55.0000 0.0
L4 Lower 73.3333 0.0
L5 Lower 91.6667 0.0
L6 Lower 110.0000 0.0
U1 Upper 18.3333 12.0
U2 Upper 36.6667 14.0
U3 Upper 55.0000 16.0
U4 Upper 73.3333 14.0
U5 Upper 91.6667 12.0
```

```
Member
L0L1 L0 L1 Section1
L1L2 L1 L2 Section1
L2L3 L2 L3 Section2
L3L4 L3 L4 Section2
L4L5 L4 L5 Section2
L5L6 L5 L6 Section2
L0U1 L0 U1 Section4
U1U2 U1 U2 Section5
U2U3 U2 U3 Section5
U3U4 U3 U4 Section5
U4U5 U4 U5 Section5
U5L6 U5 L6 Section4
L1U1 L1 U1 Section3
U1L2 U1 L2 Section6
```

T2 – Truss Input Command

The schematic of the truss reflects the modified geometry. The schematic is available by selecting the “View schematic” toolbar button  when the truss is highlighted in the Bridge Workspace tree.

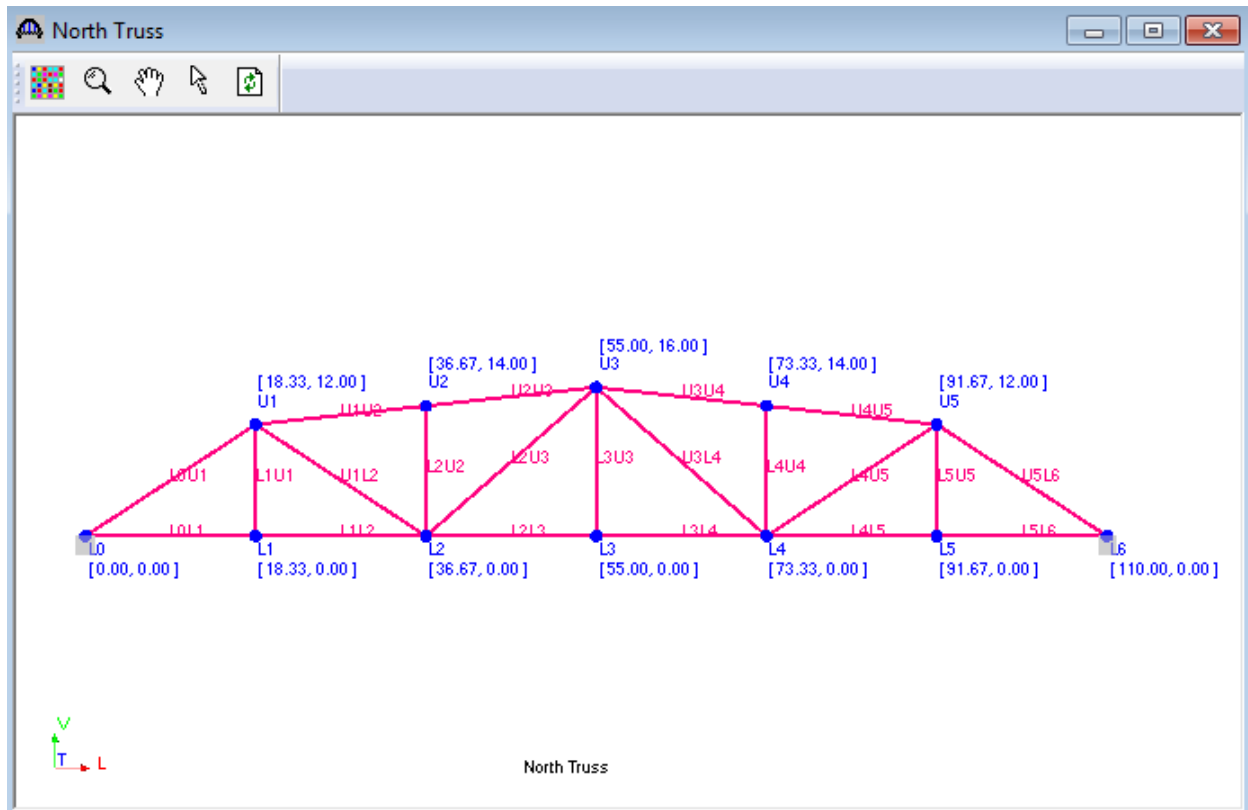

T2 – Truss Input Command

A portion of the Rating Results Report is shown below.

Bridge ID :TrussExample2
 Bridge : Truss Example 2
 StructDef : Truss(TFS)
 User : Bridge
 Date : Friday, July 15, 2016 10:57:10
 File : RatingResults.XML
 Analysis Preference Setting : None

NBI Structure ID :Truss Example 2
 Bridge Alt :
 Member : North Truss

Overall Load Factor Rating Summary

Live Load	Live Load Type	Inv Element	Inv RF	Inv Capacity (Ton)	Opr Element	Opr RF	Opr Capacity (Ton)	Legal Opr Element	Legal Opr RF
HS 20-44 - Lane	Design Lane	U5L6	2.324	83.66	U5L6	3.881	139.72		
HS 20-44 - Lane	Design Lane	U5L6	2.324	83.66	U5L6	3.881	139.72		
HS 20-44 - Truck	Design Truck	U4U5	2.108	75.88	U4U5	3.520	126.73		
HS 20-44 - Truck	Design Truck	U4U5	2.108	75.88	U4U5	3.520	126.73		

Exercise 2 Solution

The “W 12x72” is a new rolled beam shape for the bridge. We need to add this new rolled beam shape to the Bridge Workspace tree. Create a new Steel I Shape and use the Copy from Library button to copy the W12x72 to our bridge.

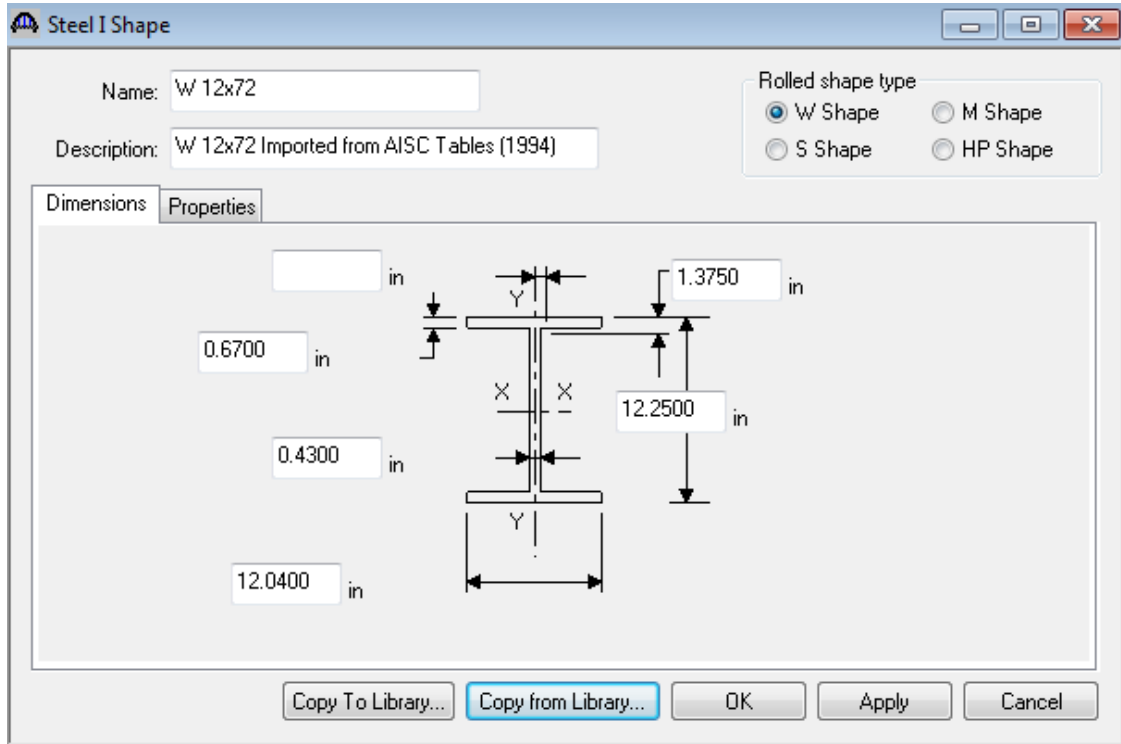

T2 – Truss Input Command

The new cross section and Member command for Exercise 2 are shown below. The new and modified descriptions are shown in bold text. The steel material is not specified for the “W 12x72”, the default steel “Truss Steel” will be used. The texts following “//” are comments and will be ignored.

```
MemberCrossSection
.
.
.
Rolled = Section7
TopFlangePlate
12.0 0.5 Steel2 // Grade 36
Beam "W 12x72" // Truss Steel
.
.
.
Member
L0L1 L0 L1 Section1
L1L2 L1 L2 Section1
L2L3 L2 L3 Section2
L3L4 L3 L4 Section2
L4L5 L4 L5 Section2
L5L6 L5 L6 Section2
L0U1 L0 U1 Section4
U1U2 U1 U2 Section5
U2U3 U2 U3 Section5
U3U4 U3 U4 Section5
U4U5 U4 U5 Section5
U5L6 U5 L6 Section4
L1U1 L1 U1 Section3
U2L1 U2 L1 Section7
L2U2 L2 U2 Section3
```

A portion of the Rating Results Report is shown below.

The screenshot shows a software window with a menu bar (File, Edit, View, Favorites, Tools, Help) and a status bar. The main content area displays the following information:

Bridge ID : TrussExample2
 Bridge : Truss Example 2
 StructDef : Exercise2Truss(TFS)
 User : Bridge
 Date : Friday, July 15, 2016 11:12:01
 File : RatingResults.XML
 Analysis Preference Setting : None

NBI Structure ID : Truss Example 2
 Bridge Alt :
 Member : North Truss

Overall Load Factor Rating Summary

Live Load	Live Load Type	Inv Element	Inv RF	Inv Capacity (Ton)	Opr Element	Opr RF	Opr Capacity (Ton)	Legal Opr Element	Legal Opr RF
HS 20-44 - Lane	Design Lane	L0U1	2.318	83.44	L0U1	3.871	139.35		
HS 20-44 - Lane	Design Lane	L0U1	2.318	83.44	L0U1	3.871	139.35		
HS 20-44 - Truck	Design Truck	U2U3	2.101	75.63	U2U3	3.509	126.31		
HS 20-44 - Truck	Design Truck	U2U3	2.101	75.63	U2U3	3.509	126.31		

Exercise 3 Solution

The new descriptions are shown in bold text. The deleted descriptions are crossed-out.

Symmetry Even

PanelPoint

```

L0 Lower 0.0000 0.0
L1 Lower 18.3333 0.0
L2 Lower 36.6667 0.0
L3 Lower 55.0000 0.0
L4 Lower 73.3333 0.0
L5 Lower 91.6667 0.0
L6 Lower 110.0000 0.0
U1 Upper 18.3333 12.0
U2 Upper 36.6667 14.0
U3 Upper 55.0000 16.0
U4 Upper 73.3333 14.0
U5 Upper 91.6667 12.0

```

Member

```

L0L1 L0 L1 Section1
L1L2 L1 L2 Section1
L2L3 L2 L3 Section2
L3L4 L3 L4 Section2
L4L5 L4 L5 Section2
L5L6 L5 L6 Section2
L0U1 L0 U1 Section4
U1U2 U1 U2 Section5
U2U3 U2 U3 Section5
U3U4 U3 U4 Section5
U4U5 U4 U5 Section5
U5L6 U5 L6 Section4
L1U1 L1 U1 Section3
U2L1 U2 L1 Section7
L2U2 L2 U2 Section3
L2U3 L2 U3 Section6
L3U3 L3 U3 Section3

```

T2 – Truss Input Command

The schematic of the truss reflects the symmetrical geometry. Only half the truss will be displayed in the schematic if the truss verification failed. The panel points and members on the right hand side are generated by the Symmetry command.

Notes for the Symmetry command:

- The command generates symmetrical geometry, user defined loads (specified in PanelPointLoad command) and supports.
- Generated symmetrical supports will be pinned supports by default (i.e. x and y translations will be restrained).
- The command will also handle supports and panel point load that are on the axis of symmetry.

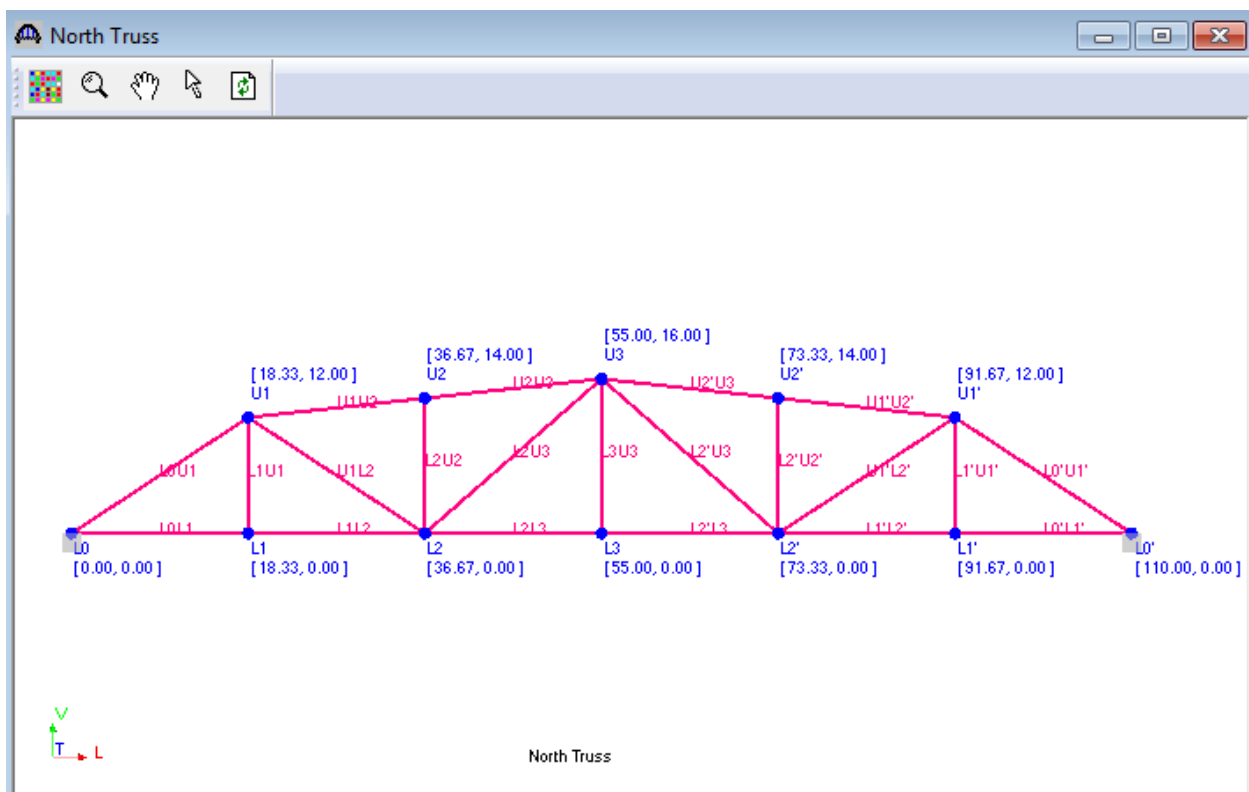

Exercise 4 Solution

The PanelPointLoad and AdditionalSelfLoad commands for Exercise 4 are shown below. The new descriptions are shown in bold text. Use “#” as a place holder for optional value if it is followed by some input.

```
Support
L0 Pinned

PanelPointLoad
L2 DC 0.0 -10.0

AdditionalSelfLoad # 5.0

LLDistribution
```

T2 – Truss Input Command

A portion of the Dead Load Analysis Report is shown below.

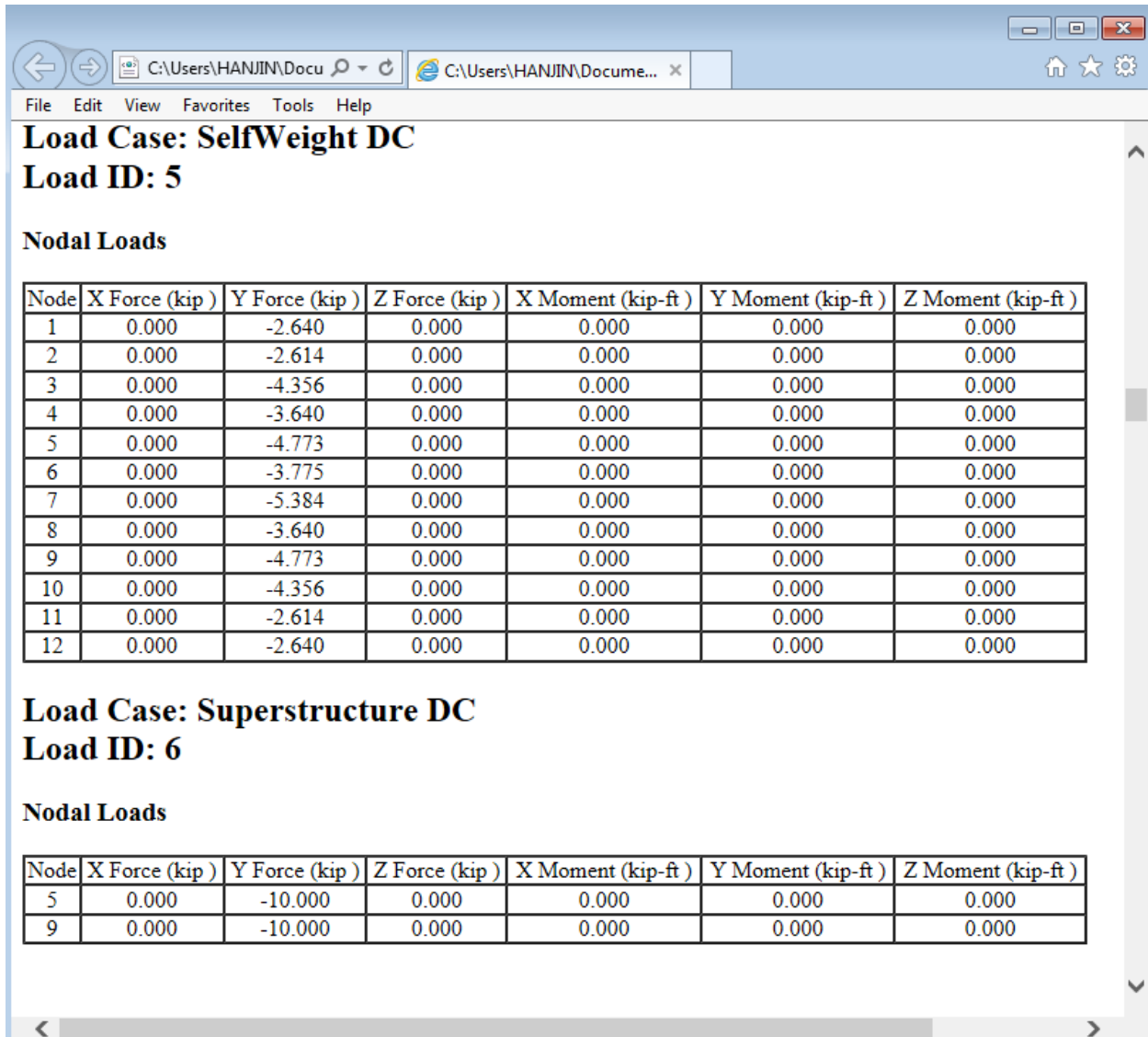

Load Case: SelfWeight DC
Load ID: 5

Nodal Loads

Node	X Force (kip)	Y Force (kip)	Z Force (kip)	X Moment (kip-ft)	Y Moment (kip-ft)	Z Moment (kip-ft)
1	0.000	-2.640	0.000	0.000	0.000	0.000
2	0.000	-2.614	0.000	0.000	0.000	0.000
3	0.000	-4.356	0.000	0.000	0.000	0.000
4	0.000	-3.640	0.000	0.000	0.000	0.000
5	0.000	-4.773	0.000	0.000	0.000	0.000
6	0.000	-3.775	0.000	0.000	0.000	0.000
7	0.000	-5.384	0.000	0.000	0.000	0.000
8	0.000	-3.640	0.000	0.000	0.000	0.000
9	0.000	-4.773	0.000	0.000	0.000	0.000
10	0.000	-4.356	0.000	0.000	0.000	0.000
11	0.000	-2.614	0.000	0.000	0.000	0.000
12	0.000	-2.640	0.000	0.000	0.000	0.000

Load Case: Superstructure DC
Load ID: 6

Nodal Loads

Node	X Force (kip)	Y Force (kip)	Z Force (kip)	X Moment (kip-ft)	Y Moment (kip-ft)	Z Moment (kip-ft)
5	0.000	-10.000	0.000	0.000	0.000	0.000
9	0.000	-10.000	0.000	0.000	0.000	0.000

A portion of the Rating Results Report is shown below.

Bridge ID :TrussExample2
 Bridge : Truss Example 2
 StructDef : Exercise4Truss(TFS)
 User : Bridge
 Date : Friday, July 15, 2016 11:17:08
 File : RatingResults.XML
 Analysis Preference Setting : None

NBI Structure ID :Truss Example 2
 Bridge Alt :
 Member : North Truss

Overall Load Factor Rating Summary

Live Load	Live Load Type	Inv Element	Inv RF	Inv Capacity (Ton)	Opr Element	Opr RF	Opr Capacity (Ton)	Legal Opr Element	Legal Opr RF	Legal Opr Capacity (Ton)
HS 20-44 - Lane	Design Lane	L0'U1'	2.249	80.96	L0'U1'	3.756	135.21			
HS 20-44 - Lane	Design Lane	L0'U1'	2.249	80.96	L0'U1'	3.756	135.21			
HS 20-44 - Truck	Design Truck	U1'U2'	2.014	72.49	U1'U2'	3.363	121.06			
HS 20-44 - Truck	Design Truck	U1'U2'	2.014	72.49	U1'U2'	3.363	121.06			

Exercise 5 Solution

The MemberOfInterest command for Exercise 5 is shown below. The new descriptions are shown in bold text.

```
LLDistribution
OneLane 0.805 0.5
MultiLane 1.27 1.0

MemberOfInterest
L0L1
Deterioration
Channels
Left Web 30.0 0.0 L0 5.0 10.0
```

A portion of the Member Section Property Report is shown below. The section properties of Member L0L1 reflect the deterioration.

Member: L0L1 - ChannelBox Section

Note:
 1. Axis 1-1 is assumed at lowest fiber of bottom flange plate.
 2. Y is measured from axis 1-1.
 3. For channels facing outwards, axis 2-2 is assumed at back of left channel section.
 4. For channels facing inwards, axis 2-2 is assumed at outermost fiber of leftmost web plate.
 5. Z is measured from axis 2-2.

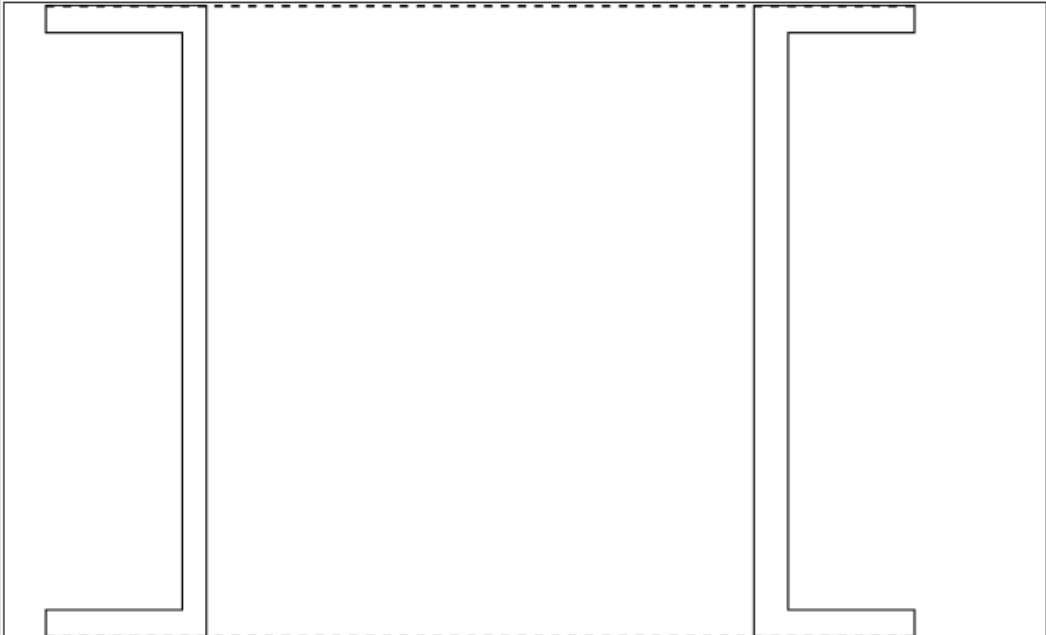

Component	Gross Area (in ²)	Y (in)	AY (in ³)	AY ² (in ⁴)	Izz _{Self} (in ⁴)	Z (in)	AZ (in ³)	AZ ² (in ⁴)	Iyy _{Self} (in ⁴)
Channel 1	12.50	7.50	93.73	702.96	377.52	-0.92	-11.44	10.46	14.20
Channel 2	16.16	7.50	121.20	909.00	429.00	13.82	223.33	2386.83	12.10
Sum	28.66		214.93	1611.96	806.52		211.90	2397.29	26.30
$Ybar_{1-1} = \text{Sum}(AY) / \text{Sum}(A) = 7.500 \text{ in}$									
$I_{1-1} = \text{Sum}(Izz_{Self}) + \text{Sum}(AY^2) = 2418.478 \text{ in}^4$									
$Izz = I_{1-1} - [\text{Sum}(A) * (Ybar_{1-1})^2] = 806.522 \text{ in}^4$									
$Zbar_{2-2} = \text{Sum}(AZ) / \text{Sum}(A) = 7.394 \text{ in}$									
$I_{2-2} = \text{Sum}(Iyy_{Self}) + \text{Sum}(AZ^2) = 2423.595 \text{ in}^4$									